



## technical data sheet

Description :

### **DATACENTER TECH SERIES CABINETS** **Front grilled door, rear grilled double door and blind side panels**

Datacenters TECH series cabinets are designed for the containment of all kinds of server computers and 19" active components that are available in the networking market. The rack can house all the 19" accessories. They are available with a width of 800 mm and a depth of 1000 or 1200 mm, provided with front grilled door, rear grilled double door and side blind panels split into 2 parts.

CODE	DESCRIPTION	DIMENSIONS (mm)				STATIC LOAD (KG)	
		W	D	H	A	With wheels	Without wheels
RAL 7021							
2009161	Cabinet 19" 800x1000x42U	800	1000	2000	911	1000	1300
2009162	Cabinet 19" 800x1200x42U	800	1200	2000	911	1000	1300



### **MAIN FEATURES**

- Steel sheet structure
- Painting: standard color Grey RAL 7021
- Front grilled (>67%) door, rear grilled (>67%) double door, opening 180°
- Side blind panels split into 2 parts with quick removal system
- Handle with key
- Ventilation unit can be installed from top outside of cabinet
- Sliding and adjustable cable entries on top and bottom
- Vertical front cable managements
- IP20 degree of protection according to EN 60259
- Nr. 4 vertical uprights in steel according to IEC 60297-1, adjustable in depth, with unit number
- Earthing kit
- Nr. 4 levelling feet
- Nr. 4 wheels (without break)
- Base is included
- Static load 1300kg, 1000 kg with wheels
- IEC 60297-2, DIN 41494 part1 and part7 compliant

**QUBIX S.p.A. Networking solutions – Via Canada, 22/A – 35127 Padova – Italy**  
Tel. +39 049 7801994 – Fax +39 049 775667 – <http://www.qubix.it>

Rev. 01-19

Qubix S.p.A. si riserva di apportare modifiche e migliorie in qualsiasi momento senza preavviso  
Qubix S.p.A. reserves the right to make changes and improvements at any time without notice



Description :

**DATACENTER TECH SERIES CABINETS**  
**Front grilled door, rear grilled double door and blind side panels**

TECHNICAL DRAWINGS

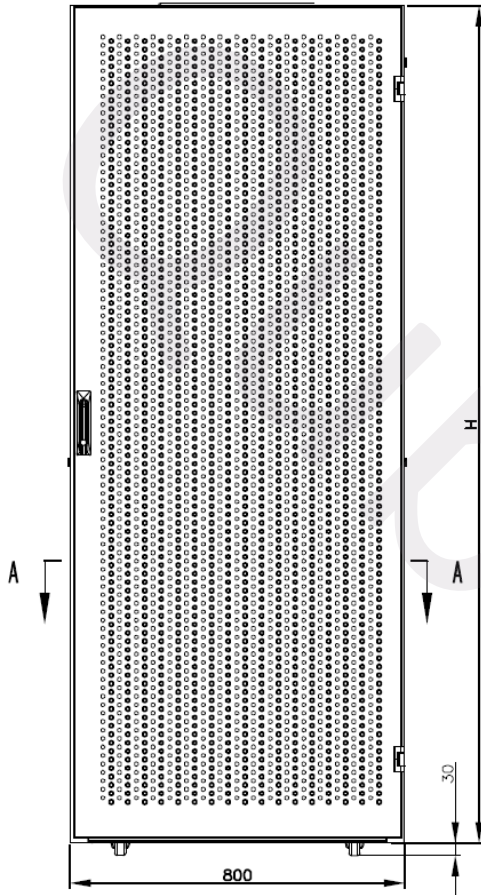

FRONT

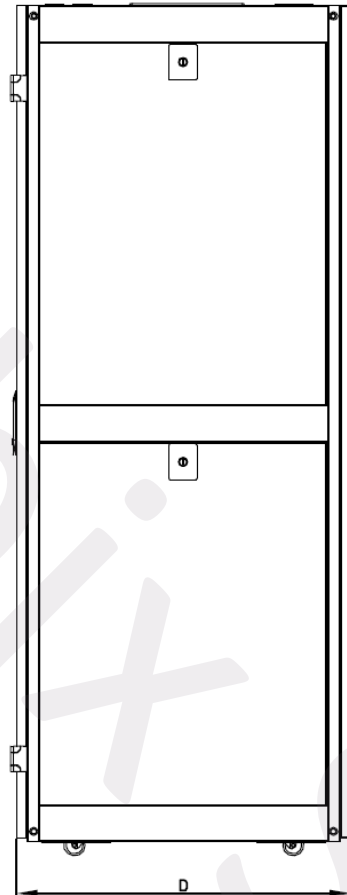

SIDE

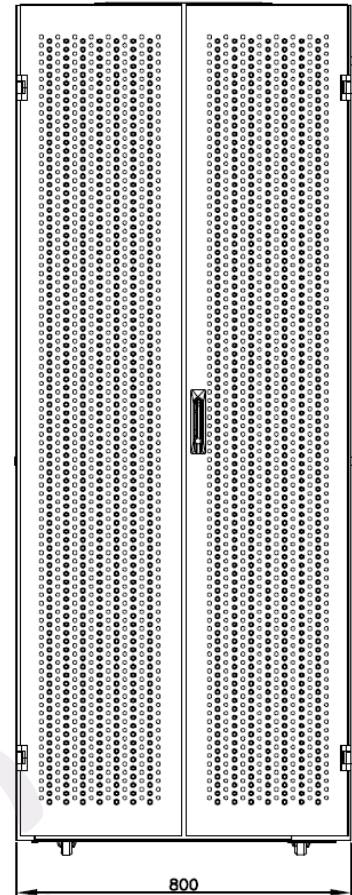

REAR

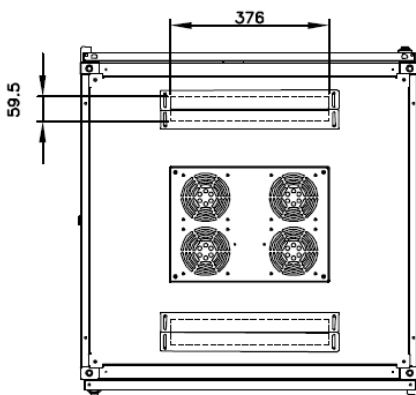

TOP

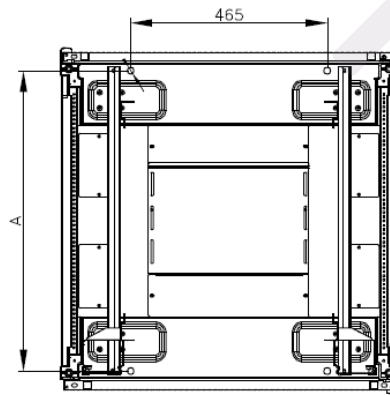

A-A

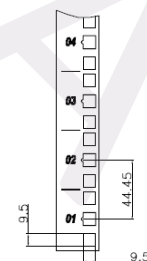

Upright detail